



Job Name: _____

Type: _____

Part #: _____

Notes: _____

LSDEM

Decorative LED Emergency Unit

STANDARD

OPTIONAL



ILLUMINATION

- Long lasting, efficient, ultra bright white LED lamp heads.
- 1W (1 LED x 1.0 watt) per head.
- Unique all inclusive lamp, reflector and lens assembly.
- Adjustable LED lamp heads provide optimal center-to-center spacing.

ELECTRICAL

- Dual 120/277 voltage.
- Charge rate/power "ON" LED indicator light and push-to-test switch for mandated code compliance testing.
- 4.8V long life, maintenance-free, rechargeable lithium ion phosphate battery.
- Internal solid-state transfer switch automatically connects the internal battery to LED lamp heads for minimum 90-minute emergency illumination.
- Fully automatic solid-state, two rate charger initiates battery charging to recharge a discharged battery in 24 hours.

MOUNTING

- Surface mount via easy connect back plate, which fits most standard junction boxes.
- Suitable for wall mount.
- Knockout for conduit applications.

HOUSING

- Injection-molded, engineering grade, 5VA flame retardant, high-impact resistant, thermoplastic in white or black finish.

OPTIONS

- SDT: Self-diagnostic feature performs monthly, biannual, and annual tests to ensure reliable operation and meet electrical and life safety codes.

WARRANTY / LISTING

- Five year warranty on all electronics and housing. Batteries pro rated for five years.
- UL listed for damp locations (0°C – 50°C).
- Meets UL924, NFPA 101 Life Safety Code, NEC, OSHA, Local and State Codes.



DIMENSIONS

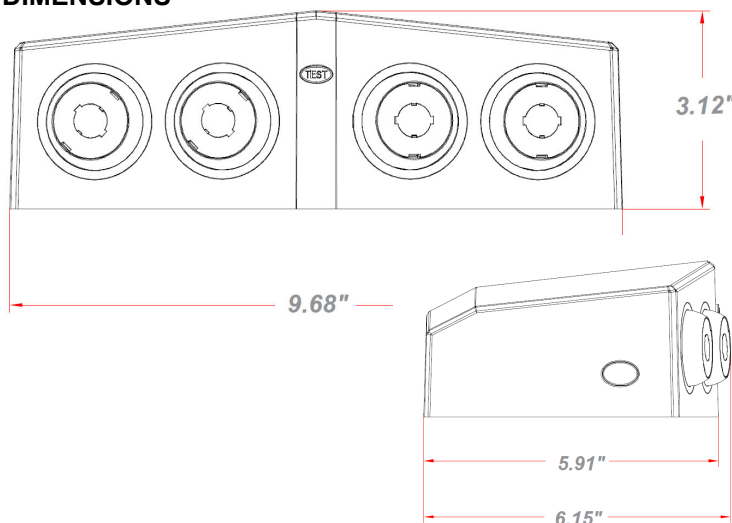

SPACING

PART#	Mounting Height (FT)	3FT Width Egress Path		6FT Width Egress Path	
		Single Fixture (ft)	Fixture To Fixture (ft)	Single Fixture (ft)	Fixture To Fixture (ft)
LSDEM	10	38	42	36	40
	12	50	50	40	41
	15	42	44	34	37

ORDERING INFORMATION

MODEL	HOUSING COLOR	OPTIONS
LSDEM	W White	SDT Self-diagnostics
	B Black	

Sample Part Number:
LSDEMWSDT