



Job Name: _____

Type: _____

Part #: _____

Notes: _____

LSHPEM

LED High Performance Emergency Thermoplastic Unit

ILLUMINATION

- Ultra-bright, energy efficient, long-life White LED adjustable lamp heads provide up to 100-ft center-to-center spacing with a 3-ft path of egress at 7-1/2-ft mounting height. Spacing:
- High performance chrome-plated metallized reflector and plastic lens.
- 5.0 watt (12 LEDs x 0.42 watt) per head.

ELECTRICAL

- Universal 120-277 voltage.
- Unique bi-color LED indicator light alerts occupant on battery condition (Red-normal, OFF-check battery).
- Charge rate/power "ON" LED indicator light and push-to-test switch for mandated code compliance testing.
- 9.6V long-life, maintenance-free, rechargeable lithium iron phosphate battery.
- Remote capacity of 3.0 watts standard.
- Internal solid-state transfer switch automatically connects the internal battery to LED lamp heads for minimum 90-minute emergency illumination.
- Fully automatic solid-state, two rate charger initiates battery charging to recharge a discharged battery in 24 hours.

MOUNTING

- Universal knockout pattern on back plate for surface mount.
- Knockouts provided for conduit feed applications.
- Suitable for wall or ceiling mount.

HOUSING

- Injection-molded, engineering grade, 5VA flame retardant, high-impact resistant, thermoplastic in white or black finish.

OPTIONS

- SDT: Self-diagnostic feature performs monthly, biannual, and annual tests to ensure reliable operation and meet electrical and life safety codes.



DIMENSIONS

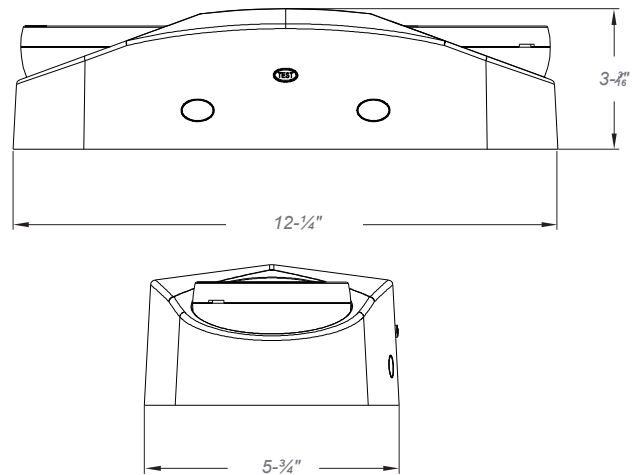

WARRANTY / LISTING

- Five-year warranty on all electronics and housing. Battery prorated for five years.
- Meets UL924, NFPA 101, Life Safety Code, NEC, OSHA, Local and State Codes.
- UL Listed for damp locations (0°C – 50°C).
- Certified to CEC under title 20 regulations.

ORDERING INFORMATION

MODEL	HOUSING COLOR		OPTIONS	
LSHPEM	W	White	SDT	Self-Diagnostics
	B	Black		