



Job Name: _____

Type: _____

Part #: _____

Notes: _____

LSBLEM-CP-CW

Constant-Power Outdoor-rated Emergency LED Driver

ILLUMINATION

- Works with or without an AC Driver to convert new or existing LED fixtures into unobtrusive emergency lighting.
- Provides constant power output to the load during emergency mode operation.
- Can be operated as NORMALLY-ON, NORMALLY-OFF or SWITCHED LOAD.
- Ideal for use with canopy lights, garage lights and any outdoor fixture that needs emergency lighting.

ELECTRICAL

- Universal 120-277V, 50/60 Hz input.
- Charge/Power "ON" LED indicator light and push-to-test switch for mandated code compliance testing.
- Long-life, maintenance free, rechargeable NiCad battery.
- Output short/overcurrent protection: Electronic limiting, with normal operation resuming upon removal of fault.
- 90-minute minimum emergency operating time over full temperature range.
- Output classification: Class 2 Compliant.
- Surge protection: Per C62.41 (TVS).
- Input overcurrent protection: Fusible link.
- 24 hour maximum battery recharge time.

HOUSING

- Low-profile, unobtrusive design.
- LED illuminated and remote mounted test switch.
- Sealed and gasketed, powder-coated, die-cast aluminum housing.
- Provided with 2-ft flex conduit and conduit hub.

MOUNTING

- Suitable for installation as top, or side mount of the LED fixture.

WARRANTY/LISTING

- UL Listed for factory or field installation.
- Suitable for wet locations (-20°C - 50°C).
- Five year warranty on all electronics and housing.
- Meets UL924, NFPA 101 Life Safety Code, NEC, OSHA, Local and State codes.
- Certified to CEC under Title 20 regulations.



DIMENSIONS

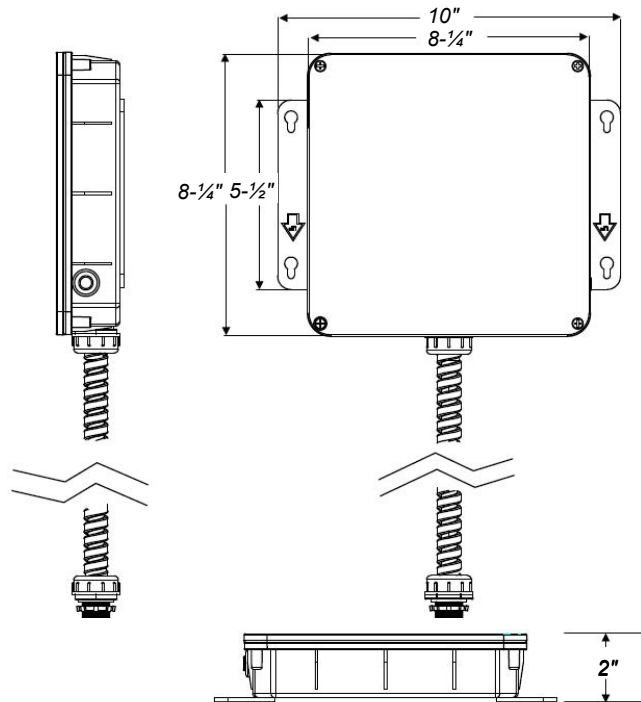

ORDERING INFORMATION

MODEL	OUTPUT POWER
LSBLEM-CP-CW	(blank) 17.0 Watts



Job Name: _____

Type: _____

Part #: _____

Notes: _____

ELECTRICAL INFORMATION

MODEL	INPUT CURRENT (A)	INPUT POWER (W)	OUTPUT VOLTAGE (V)	OUTPUT POWER (W)	OUTPUT CURRENT (mA)
LSBLEM-CP-CW	0.11	7.9	20-50	17.0	850-340

Coordination Guidelines

These guidelines were developed to allow the lighting system Designer/Specifier to predict the operating performance levels of LED luminaires when powered by an electrically compatible emergency driver. It is ultimately the responsibility of the Designer/Specifier to ensure that the as installed system delivers the code-compliant path of egress illumination.

1) Determine Electrical Compatibility

- A) Verify that the Luminaire LED Driver, where applicable, is Class 2 compliant.
- B) Verify that the Luminaire LED Lamp(s) have an operating voltage between 20Vdc and 50Vdc range.
- C) Verify that the Luminaire LED Lamp(s) have a power rating equal to, or greater than, the emergency power rating of the emergency driver under consideration (refer to the Electrical Information section).

2) Calculate Lumen Output During Emergency Operation

- A) Access luminaire data by logging onto Design Lites Consortium (www.designlights.org).
- B) Select "Search the DLC Qualified Product List" on the DLC homepage.
- C) Enter manufacturer name and P/N of luminaire under consideration in the "search by keyword" text window.
- D) Select "Search" tab to open the "Qualified Products List".
- E) Determine luminaire Lumens per Watt efficacy in "Rated Data" specifications.
- F) Multiply luminaire Lumens per Watt by Emergency Output of the emergency driver under consideration (refer to the Electrical Information section). This figure is the Lumens available from the luminaire during emergency operation.

3) Determine Suitability of Means of Egress Lighting Levels

- A) Using industry standard lighting design software, along with IES files for the luminaire under consideration, verify that the as installed available Lumens (as calculated in 2F above) are sufficient to meet Code-compliant path of egress illumination levels.

While the emergency driver series has been found compliant with the requirements of UL Standard 924, it is ultimately the responsibility of the Designer/Specifier to ensure the as-installed system delivers code-compliant path of egress illumination in accordance with Federal, State or local municipal requirements.