



Job Name: \_\_\_\_\_

Type: \_\_\_\_\_

Part #: \_\_\_\_\_

Notes: \_\_\_\_\_

# LSLEMCP

Constant-Power Emergency LED Driver  
with & without conduit

## ILLUMINATION

- Works with or without an AC driver to convert new or existing LED fixtures into unobtrusive emergency lighting.
- Provides constant power output to the load during emergency mode operation.
- Designed to operate NORMALLY-ON, NORMALLY-OFF or SWITCHED LOAD fixtures.

## ELECTRICAL

- Universal 120-277V, 50/60 Hz input.
- Charge/Power "ON" LED indicator light and push-to-test switch for mandated code compliance testing.
- Long-life, maintenance free, rechargeable lithium iron phosphate battery.
- Output short/overcurrent protection: Electronic limiting, with normal operation resuming upon removal of fault.
- 90-minute minimum emergency operating time over full temperature range.
- Output classification: Class 2 Compliant.
- Surge protection: Per C62.41 (TVS).
- Input overcurrent protection: Fusible link.
- 24 hour maximum battery recharge time.

## HOUSING

- LED illuminated and remote mounted test switch.
- Low profile galvanized steel construction.
- Compact design allows for installation of non-conduit models, inside most LED fixtures.

## MOUNTING

- Standard models suitable for inside or top mount of LED fixtures
- Conduit models suitable for remote mount to LED fixture

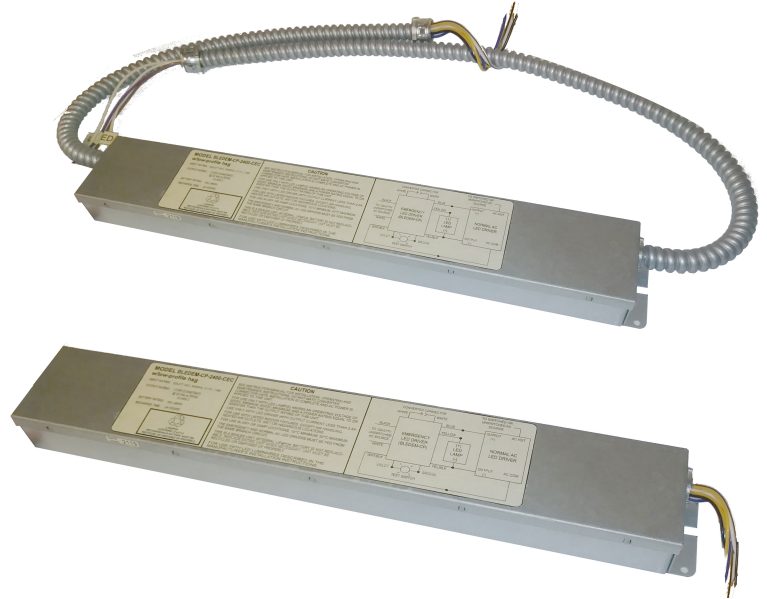

## DIMENSIONS

LSLEM-CP-5/5C

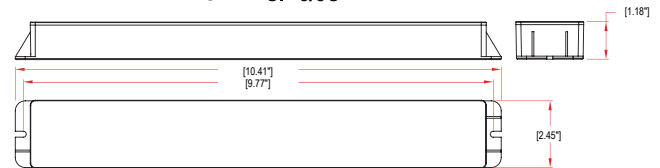

LSLEM-CP-10/10C & 13/13C

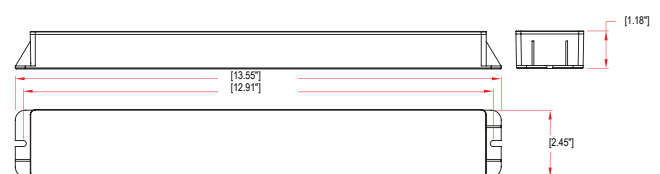

## WARRANTY/LISTING

- UL Listed for factory or field installation.
- Suitable for damp locations (10°C - 55°C).
- Five year warranty on all electronics and housing.
- Meets UL924, NFPA 101 Life Safety Code, NEC, OSHA, Local and State codes.
- Certified to CEC under Title 20 regulations.

## ORDERING INFORMATION

Sample Part Number: **LSLEM-CP-5C**

<sup>1</sup> When battery packs are remote-mounted, the remote distance cannot exceed 1/2 of the distance from driver to LED load specified by the A.C. driver manufacturer. **The maximum allowable remote mounting distance is 20 feet.**

MODEL	OUTPUT POWER		OPTIONS	
LSLEM-CP	-5	5.0 Watts	C	provided with 2-ft conduit on each end <sup>1</sup>
	-10	10.7 Watts		
	-13	13.7 Watts		

## ELECTRICAL INFORMATION

MODEL	INPUT CURRENT (A)	INPUT POWER (W)	OUTPUT VOLTAGE (V)	OUTPUT POWER (W)	OUTPUT CURRENT (mA)
LSLEMCP-5/5C	0.061	3.9	20-50	5.0	250-100
LSLEMCP-10/10C	0.087	5.7	20-50	10.7	535-214
LSLEMCP-13/13C	0.110	6.9	20-50	13.7	685-214

## WIRING DIAGRAM

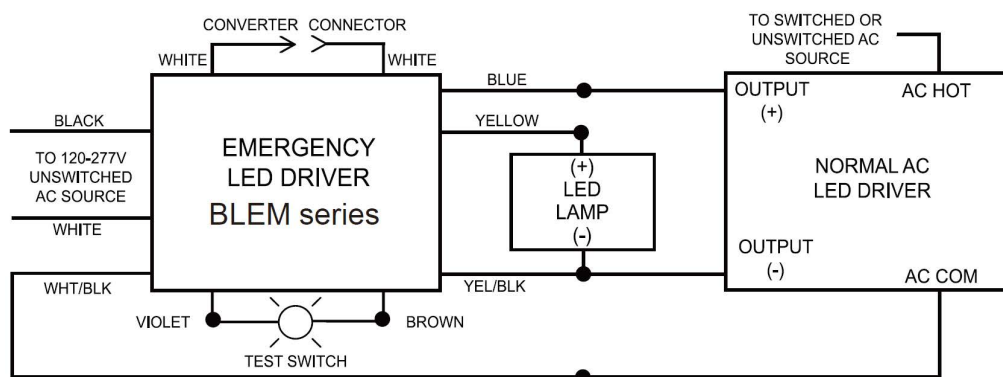

## LSLEMCP Series System Coordination Guidelines

These guidelines were developed to allow the lighting system Designer/Specifier to predict the operating performance levels of LED luminaires when powered by an electrically compatible LSLEM-CP series model. It is ultimately the responsibility of the Designer/Specifier to ensure that the as installed system delivers the code-compliant path of egress illumination.

### 1) Determine Electrical Compatibility

- Verify that the Luminaire LED Driver, where applicable, is Class 2 compliant.
- Verify that the Luminaire LED Lamp(s) have an operating voltage between 20Vdc and 50Vdc range.
- Verify that the Luminaire LED Lamp(s) have a power rating equal to, or greater than, the emergency power rating of the LSLEM-CP model under consideration (refer to the Electrical Information section).

### 2) Calculate Lumen Output During Emergency Operation

- Access luminaire data by logging onto Design Lites Consortium ([www.designlights.org](http://www.designlights.org)).
- Select "Search the DLC Qualified Product List" on the DLC homepage.
- Enter manufacturer name and P/N of luminaire under consideration in the "search by keyword" text window.
- Select "Search" tab to open the "Qualified Products List".
- Determine luminaire Lumens per Watt efficacy in "Rated Data" specifications.
- Multiply luminaire Lumens per Watt by Emergency Output of the HLEMCP model under consideration (refer to the Electrical Information section). This figure is the Lumens available from the luminaire during emergency operation.

### 3) Determine Suitability of Means of Egress Lighting Levels

- Using industry standard lighting design software, along with IES files for the luminaire under consideration, verify that the as installed available Lumens (as calculated in 2F above) are sufficient to meet Code-compliant path of egress illumination levels.

*While the LSLEM-CP series has been found compliant with the requirements of UL Standard 924, it is ultimately the responsibility of the Designer/Specifier to ensure the as-installed system delivers code-compliant path of egress illumination in accordance with Federal, State or local municipal requirements.*