



Job Name: \_\_\_\_\_

Type: \_\_\_\_\_

Part #: \_\_\_\_\_

Notes: \_\_\_\_\_

# LSMCD

**Internal Specifications:** The LSMCD UNIT has a standard 120/277V input. The solid state, high efficiency, dual rate charger provides precise float voltage control and incorporates a low voltage disconnect for optimum protection. Fuse protection is standard.

**External Specifications:** The durable NEMA 4X fiberglass enclosure is corrosion and vandal resistant. The housing is fully gasketed and is supplied standard in an industrial gray finish. The LSMCD UNIT can be surface mounted on a wall. Magnetic test switch and LED status indicator are standard

**Emergency Heads:** As standard, the LSMCD UNIT is supplied with two (2) top mounted, weatherproof PAR36 style emergency heads. Constructed of high impact thermoplastic and finished in a neutral gray finish. The emergency head design features a locking collar that securely holds the lens in place and facilitates quick re-lamping.

**Electrical Specifications: BATTERY:** The LSMCD UNIT is designed with maintenance free, sealed lead acid batteries providing a minimum emergency duration of 90 minutes. Recharge time for the battery is forty-eight [48] hours. Optional nickel cadmium batteries are available. The maximum battery operating temperature is +40°C and the minimum is +10°C.

**CIRCUIT:** The LSMCD UNIT utilizes a high-efficiency two stage charger providing precise float voltage control with low voltage disconnect protection. All components used in the circuitry are temperature compensated. The charger also has brownout and short circuit protection. Charger status is easily determined via a dual diagnostic LED display which indicates AC/ON and High Charge. A magnetic test switch allows maintenance personnel to quickly determine the operational status of the unit and lamp load, (magnet included).



Dimensions (in,mm)

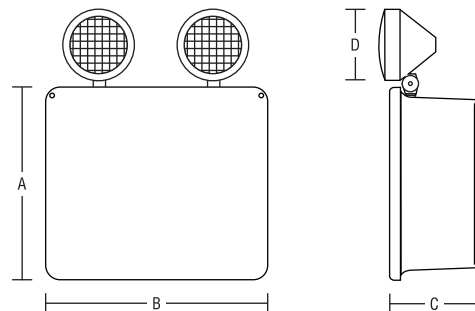

| Series | A     | B     | C     | D     |
|--------|-------|-------|-------|-------|
| LSMCD  | 13.5" | 15.5" | 6.25" | 5.5"  |
|        | 343mm | 394mm | 159mm | 140mm |

## Ordering Logic

| Series  | Operation     | Pb-A <sup>[1]</sup> (Capacity) | Ni-Cd <sup>[2]</sup> (Capacity) | Emergency Heads    | Lamps        | Options  |
|---------|---------------|--------------------------------|---------------------------------|--------------------|--------------|--|
| LSMCD-U | 6 (6V)        | 36 (6V, 12V)                   | 42 (6V, 12V)                    | 4LR (quad PAR36)   | See lamps    | AT (autotest)  |
|         | 12 (12V)      | 60 (6V, 12V)                   | 54 (6V)                         | 3LR (triple PAR36) | selection on | NC <sup>[3]</sup> (nickel-cadmium battery)             |
|         |               | 72 (6V)                        | 90 (6V, 12V)                    | 2LR (double PAR36) | next page    | TD <sup>[4]</sup> (time delay- specify 5, 10, 20 mins) |
|         | 100 (6V)      | 130 (12V)                      | 1LR (single PAR36)              |                    |              | TP (tamper proof screws)                               |
|         | 120 (6V, 12V) |                                | 0 (no heads)                    |                    |              | AM (ammeter)   |
|         | 140 (12V)     |                                |                                 |                    |              | VM (voltmeter)   |
|         |               |                                |                                 |                    |              | FAI <sup>[5]</sup> (fire alarm interface)              |
|         |               |                                |                                 |                    |              | SMH (side mount heads)                                 |
|         |               |                                |                                 |                    |              | WG (wireguard)   |

[1]NOTE: Sealed lead calcium.

[2]NOTE: Nickel-cadmium. Must select NC from options when selecting Ni-Cd.

[3]NOTE: NC (select wattage/voltage from Ni-Cd column).

[4]NOTE: Must specify at time of order, 10 min standard.

[5]NOTE: Specify type- open/closed dry contact.

EXAMPLE: LSMCD-12-72-2LRWP-8WH-WG

DESCRIPTION: 12V, 72W, two Par36 heads, 2x8W halogen lamps, wireguard.



Job Name: \_\_\_\_\_

Type: \_\_\_\_\_

Part #: \_\_\_\_\_

Notes: \_\_\_\_\_

**Mechanical Specifications:**

The LSMCD UNIT housing is constructed from durable, corrosion resistant fiberglass. The housing is fully gasketed for harsh and hazardous locations. The front access panel/door is hinged for trouble-free installation and maintenance. The LSMCD UNIT features a stainless steel breather valve that proves efficient ventilation. Remote lamp loads are connected to the emergency power supply with sturdy terminal connectors.

The LSMCD has been designed to perform in applications where the environment would punish any standard unit. The entire internal cavity of the sign is protected from moisture ingress by an extremely resilient gasket. The gasketing always holds its original form and has “memory retention” so that it effectively and consistently protects the LSMCD from moisture.

**Autotest:**

The Autotest feature automatically performs a 5 minute discharge test monthly. Every 6 months, two 90 minute discharge tests are performed 24 hours apart. This tests both the battery capacity and recharge capability. The status of the LSMCD UNIT is communicated clearly with a single, multi-color LED indicator.

**Hazardous Approvals:**

The LSMCD series is approved for use in Class 1, Division 2, Groups A, B, C and D: T2B area classification. In addition, the LSMCD is also suitable for Class I, Zone 2, IIA, IIB & IIC: T1 & T2 area classification.

**Warranty:**

The LSMCD UNIT comes with a 3-year factory warranty. Lamps are not covered under the warranty. Deliberate damage, misuse, improper installation effectively cancel the warranty.

**Lamp selection: (ONLY PAR36 STYLE HEADS AVAILABLE)**

|                         | 6V  | 12V    |
|-------------------------|-----|--------|
| Composite Tungsten      | 9W  | 9, 18W |
| Sealed Beam LED (LEDSB) | N/A | 6W     |

**model rating guide**

| Model        | Voltage | Wattage |        |        |        |
|--------------|---------|---------|--------|--------|--------|
|              |         | 90min   | 120min | 180min | 240min |
| LSMCD-6-36   | 6       | 36      | 27     | 18     | 13     |
| LSMCD-6-42   | 6       | 42      | 31     | 21     | 15     |
| LSMCD-6-54   | 6       | 54      | 40     | 27     | 20     |
| LSMCD-6-60   | 6       | 60      | 45     | 30     | 22     |
| LSMCD-6-72   | 6       | 72      | 54     | 36     | 27     |
| LSMCD-6-90   | 6       | 90      | 67     | 45     | 33     |
| LSMCD-6-100  | 6       | 100     | 75     | 50     | 25     |
| LSMCD-6-120  | 6       | 120     | 90     | 60     | 45     |
| LSMCD-12-36  | 12      | 36      | 27     | 18     | 13     |
| LSMCD-12-42  | 12      | 42      | 31     | 21     | 15     |
| LSMCD-12-60  | 12      | 60      | 45     | 30     | 22     |
| LSMCD-12-90  | 12      | 90      | 67     | 45     | 33     |
| LSMCD-12-120 | 12      | 120     | 90     | 60     | 45     |
| LSMCD-12-130 | 12      | 130     | 97     | 65     | 48     |
| LSMCD-12-140 | 12      | 140     | 105    | 70     | 52     |