



Job Name: \_\_\_\_\_

Type: \_\_\_\_\_

Part #: \_\_\_\_\_

Notes: \_\_\_\_\_

# LSM6

## Semi-Recessed MR-16 Emergency Unit

### ILLUMINATION :

- Two fully adjustable semi-recessed, round MR16 lamp heads for optimal light distribution
- Ultra-bright, energy efficient, long-life White LED lamps provide up to 76-ft center-to-center spacing with 3-ft path of egress at 7.5-ft mounting height.

### ELECTRICAL:

- Dual 120/277 voltage.
- Charge rate/power "ON" LED indicator light and push-to-test switch for mandated code compliance testing.
- LVD (low voltage disconnect) prevents battery from deep discharge.
- 6V maintenance-free, rechargeable sealed lead acid battery.
- Internal solid-state transfer switch automatically connects the internal battery to lamp heads for minimum 90-minute emergency illumination.
- Fully automatic solid-state, two rate charger initiates battery charging to recharge a discharged battery in 24 hours.

### MOUNTING:

- Universal knockout pattern on the backplate for wall mount. Snaps into place making internal electrical connections.
- Knockout for conduit applications.

### HOUSING :

- Injection-molded, engineering grade, 5VA flame retardant, high-impact resistant, thermoplastic in white or black finish.
- OPTIONS: USA: Substantial transformation assembly in the U.S. complies with "Assembled in the USA" under the Buy American Act.

### WARRANTY / LISTING:

- Five year warranty on all electronics and housing. Battery prorated for two years.
- Meets UL924, NFPA 101 Life Safety Code, NEC, OSHA, Local and State Codes.
- UL Listed for damp locations (20°C – 40°C).



### DIMENSIONS

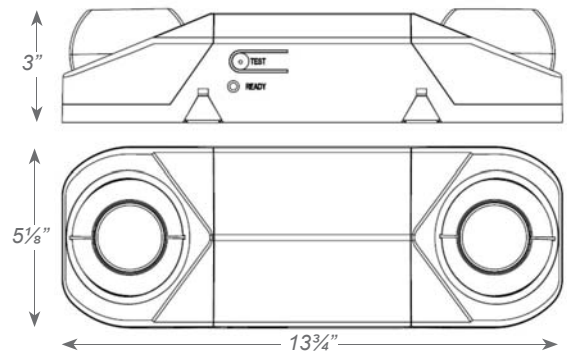

### ELECTRICAL INFORMATION

CATALOG NUMBER	INPUT WATTS (W)		INPUT AMPS (A)	
	120V	277V	120V	277V
LSM6	4.2	5.2	0.039	0.021

STANDARD	OPTIONAL

### ORDERING INFORMATION

Sample Part Number: SEEM6-PLED

MODEL	HOUSING COLOR	LAMP	OPTIONS
LSM6	(blank) White B Black	PLED 7.0W High Lumen White LED Lamps standard	USA Assembled in USA