



Job Name: \_\_\_\_\_

Type: \_\_\_\_\_

Part #: \_\_\_\_\_

Notes: \_\_\_\_\_

# LSMPS Series Inverters

## Emergency Micro Power Systems

### DESCRIPTION:

- LSMPS Series inverter systems are designed to provide sinusoidal AC emergency power to connected incandescent, fluorescent or LED fixtures of between 20 and 55 watts
- Surface, recessed or ceiling T-Grid mount models are designed for easy installation either on or near controlled fixtures. LSMPS models support Normally-ON, Normally-OFF, switched operation or any combination thereof (see Wiring Diagrams section)

### ELECTRICAL SPECIFICATIONS:

#### Input:

- Input Voltages: 120 or 277VAC  $\pm 10\%$
- Input Frequencies: 60Hz  $\pm 2\%$
- Input Protection: Provided by Service Panel, Rated 20A max.

#### Output:

- Output Voltages: 120 or 277VAC (60Hz)
- Efficiency Rating: 98% at full rated load (line)
- Waveform: Sinusoidal (digitally controlled, PWM design)
- Static Voltage:  $\pm 5\%$  during battery discharge. 0-100% linear load.
- Output Frequencies: 60Hz.  $\pm 0.3\text{Hz}$  during emergency cycle
- Output Distortion: Less than 3% THD (linear load)
- Transfer Time: Less than 1.0 second
- Load Power Factor Range: 0.44 Lead to 0.44 Lag
- Minimum Loading: 0% of rated system capacity
- Output Protection: Inverter fuse

### HOUSING:

- Heavy duty steel cabinet is finished in white baked-on powder paint providing scratch and corrosion resistance
- Optional paint color (-SP) finishes available, consult factory

### MOUNTING:

**Surface Mount:** Surface mount models are designed for mounting to walls by means of keyhole slots provided in the back of the unit housing.

**Recess Mount:** Recess models provide recess mounting holes on both sides of the enclosure.

**T-Grid Mount:** Housing design allows simple drop-in installation between t-grid runs. Safety wires (supplied by others) are required for attachment to building structure.

### WARRANTY / LISTING:

- Unit:** (excluding lamps) Full coverage against defects in materials and workmanship for 3 years from date of shipment.
- Battery:** 3 years Lead-Acid, 5 yrs NiCd full warranty plus an additional 7 years of prorated coverage.
- All models are UL924 Listed and meet NFPA 101 Life Safety Code, NEC, OSHA, Local and State Codes. Optional T-Grid models are plenum rated, to UL2043 and meets city of Chicago CCEA Requirements.
- UL Listed for damp locations (0° – 50°C for NiCad models and 20° – 30°C for lead-calcium models).
- Optional -CEC models are Certified to CEC Under Title 20 regulations
- FCC Part 15 Class B Compliant



Surface Mount Models

True Sinusoidal Output Power

### DIMENSIONS

#### Standard Surface Mount Housings

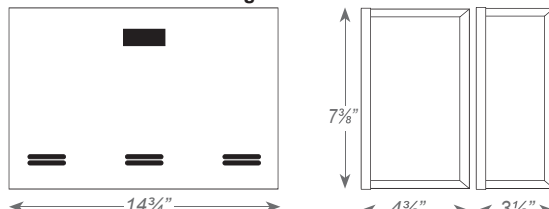

#### Recessed Mount Housings

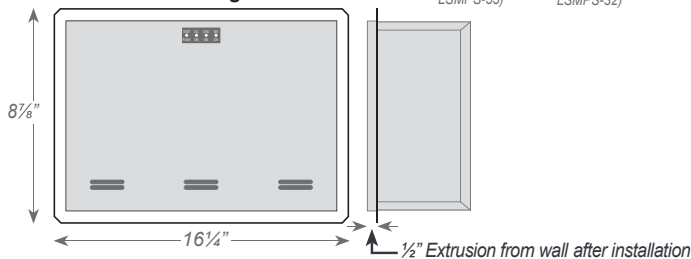

#### Optional Ceiling T-grid Mount Housing

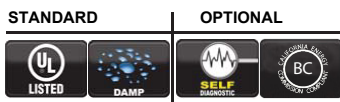
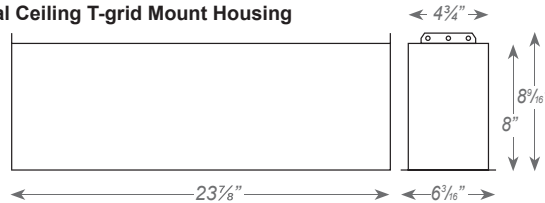

2024.09



Job Name: \_\_\_\_\_

Type: \_\_\_\_\_

Part #: \_\_\_\_\_

Notes: \_\_\_\_\_

The LSMPS Series is designed to provide 20W to 55W of emergency power to incandescent, fluorescent, and/or LED fixtures. The LSMPS unit provides clean, sinusoidal AC output power allowing it to be remotely mounted up to 1,000 feet away from the controlled fixture(s). Unlike a ballast fluorescent emergency pack, the LSMPS provides power to the input side of the fixture, (including the ballast) eliminating any chance of incompatibility. LSMPS Series models are available for surface, recessed or ceiling T-Grid mounting if required. All LSMPS systems will provide emergency power output for a minimum of 90-minutes.

**FEATURES:**

- For powering incandescent, fluorescent, and LED fixtures \*
- True sinusoidal AC pulse width modulated (PWM) design provides clean 60Hz. emergency output
- Universal 120/277VAC, 60Hz. input/output
- Unit capacities of 20W to 55W
- "Soft Start" design reduces fixture inrush current
- Surface, recessed or T-Grid mount models
- Lumen output from fixture is 100% of nominal
- Unique design eliminates compatibility problems with LED drivers as well as fluorescent ballasts
- Normally-ON and/or Normally-OFF load output
- Provisions for local switching capability - Always-ON during emergency conditions regardless of local switch position
- Temperature compensated, dual-mode charger includes low voltage disconnect feature to provide protection against battery deep discharge
- Maintenance-free Lead-Calcium and premium grade Nickel-Cadmium battery models offered
- Control panel with momentary test switch, AC-ON, Charge-ON and Inverter-ON LED indicators
- Battery circuit fuse protected
- Reverse battery and AC lockout protection

\* Consult factory for compatibility for other lamp types

**OPERATION :** Upon failure of the normal utility power the LSMPS unit is automatically turned on by a solid-state switching circuit and provides a minimum of 90-minutes of emergency power to the connected load. Lumen output will be maintained at 100% of the lamp s rating throughout the entire duration.

A solid-state low voltage disconnect circuit is used to protect the battery from being severely damaged by a deep discharge. When normal utility power is restored, the unit switches the load back to normal utility operation and the fully automatic, temperature compensated, dual mode charger begins to restore the battery bringing it to full charge within UL92 speci ed parameters. A brownout sensing circuit insures proper operation during "low line" conditions.



**WIRING:** Connection to an unswitched AC circuit is required by the NEC. Wiring access is provided for by conduit knockouts in the unit housing. LSMPS Series models also provide knockouts in the back of the housing for rear wiring from standard electrical boxes when surface mounting.

**LOAD COMPATIBILITY:** Connection to an unswitched AC circuit is required by the NEC. Wiring access is provided for by conduit knockouts in the unit housing. LSMPS Series models also provide knockouts in the back of the housing for rear wiring from standard electrical boxes when surface mounting.

**SYSTEM OPTIONS** <sup>(1) (2)</sup>

ADD SUFFIX	DESCRIPTION
-S	Surface Mount Housing
-R	Recess Mount Housing
-T	Plenum Rated Ceiling T-Grid Mount Housing
-SP	Special Housing Color (specify)
-RTS	Remote Test Switch Panel <sup>(3)(4)</sup>
-SDT	Self-Testing / Self-Diagnostics <sup>(3)</sup>
-CEC	Title 20 Compliant <sup>(5)</sup>

(1) Other options available. Consult factory.  
 (2) Some options may impact product UL listing. Consult factory.  
 ( ) For more information, separate specification sheets are available on the -RTS and -SDT options. Consult factory.  
 ( ) Shipped separately as an accessory  
 (5) Only available with - 2 and -55 models

**GENERAL SPECIFICATIONS**

MODEL NUMBER	HOUSING SIZE	INPUT / OUT-PUT VOLTS	90 min. CAPACITY (Watts/VA)	SYSTEM WEIGHT*		BATTERY TYPE	TEMP. RANGE (°C)	POWER CONSUM. (Max.)	BATTERY VOLTAGE (VDC)	DC INPUT CURRENT (Adc)	INPUT CURRENT		THERMAL OUTPUT in BTUs	
				Lbs.	Kg.						120VAC (max)	277VAC (max)	STANDBY	EMERGENCY
LSMPS-32	Small	120/277	32/32	14.0	6.4	Lead-Calc	20-30°	9W	12	3.4	0.34A	0.15A	7	32
LSMPS-55	Large	120/277	55/55	18.0	8.2	Lead-Calc	20-30°	9W	12	5.7	0.54A	0.23A	7	47
LSMPS-20	Small	120/277	20/20	11.0	5.0	NiCad	0-50°	9W	12	2.1	0.25A	0.11A	31	22
LSMPS-35	Large	120/277	35/35	12.0	5.4	NiCad	0-50°	9W	12	3.8	0.37A	0.16A	31	35

\* System weights shown include installed batteries



Job Name: \_\_\_\_\_

Type: \_\_\_\_\_

Part #: \_\_\_\_\_

Notes: \_\_\_\_\_

**BATTERIES AND CHARGER**

**Battery:** Sealed Lead Calcium (10 year life)

**Battery Voltage:** 24VDC for SPS-55/125, SPS-110/125 models and 48VDC for SPS110/250, SPS220/250 models

**Runtime:** 90-minutes standard - based on battery performance at (25°C). Other runtimes available, consult factory.

**Battery Protection:** Low Voltage Battery Disconnect protects the battery from being severely damaged by deep discharge during prolonged power failures.

DC Overload and Short Circuit Protection provided by a DC input breaker and fuse.

**Charger**

**Charger Type:** Fully automatic, temperature compensated, dual-mode charger

Power Consumption (Charger Only):

15W maximum (2.5W in standby) for SPS-55/125, and SPS-110/125 models

30W maximum (5W in standby) for SPS110/250, and SPS220/250 models

**Recharge Duty Cycle:** Meets UL924 requirements

**Battery Circuit Breaker:** Also used as battery isolator

**Controls:** Momentary test switch, AC-ON,

Charge-ON and Inverter-ON LED indicator lights

**Safety Circuitry:** AC Lockout prevents battery discharge prior to initial unit power-up.

Brownout Protection automatically switches the unit to emergency mode when utility

voltage is significantly reduced

**Environmental**

**Altitude:** < 10,000 feet (3,000m) above sea level without derating.

Operating Temperature Range: 20°C to 30°C

*NOTE: Optimum system performance between 20°C and 30°C; temperatures outside of this range will affect battery performance and life. Relative Humidity: 95% non-condensing*

**SYSTEM STATUS MONITORING PANEL**

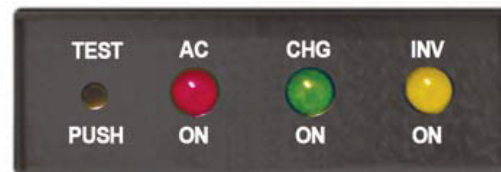

*All LSMPS systems provide a monitoring panel on the front of the unit to show operating status at all times. The panel provides a test switch for user initiated system tests and a 3-LED array that provides an intuitive visual indication of unit readiness.*

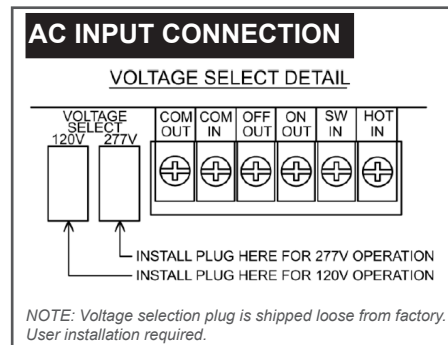

**IMPROVED AESTHETICS** The LSMPS system’s sinusoidal AC output design eliminates voltage drop and proximity concerns. This allows added flexibility in installation location as LSMPS units can be installed hundreds of feet from the units they power. This means LSMPS units to be located conveniently out of sight in closets or utility rooms without interrupting architectural aesthetics.

In lighting applications, no special or additional emergency fixtures are necessary. Simply designate and connect existing lighting fixtures, either interior or exterior, to the LSMPS unit for emergency operation eliminating the need for exposed, stand-alone emergency luminaires.

**LSMPS SYSTEM ADVANTAGES:** Compared to traditional discrete emergency lighting units, the LSMPS Series provides emergency illumination from a single power source resulting in lower maintenance overhead and routine testing expenses.

LSMPS units lower installation costs by powering existing lighting fixtures during emergencies. And because connected fixtures are driven at full brilliancy, they provide far superior egress lighting and deliver improved occupant safety.



Job Name: \_\_\_\_\_

Type: \_\_\_\_\_

Part #: \_\_\_\_\_

Notes: \_\_\_\_\_

**SUGGESTED SPECIFICATIONS :**

An inverter system with sinusoidal output shall be supplied capable of powering any combination of lighting fixtures, including incandescent, fluorescent, induction and/or LED light sources without compatibility problems.

The system shall transfer in less than 1.0 second to reliably back up lighting fixtures without loss of illumination and operate any and all connected lighting fixtures at full lumen output during the complete 90-minute discharge cycle.

The input voltage shall be the same as the output voltage and shall be single phase 120/277 volts, 60Hz. Output capacity will be (20 Watts/32 Watts) / (35 Watts/55 Watts) for a minimum duration of 90-minutes.

The design shall be a standby, off-line inverter with on-line efficiency of 98%; on-line double conversion UPS systems shall not be considered acceptable alternatives. LSMPs system output shall be a PWM generated sine wave with less than 3% total harmonic distortion with "Soft-Start" design reducing fixture inrush current. The system shall also provide short circuit and overload protection as standard.

An intuitive three LED display shall provide system operational information at a glance and alert user to any malfunction in system performance. Authorized maintenance personnel shall have access to the system's controls while being protected from any live exposed connections.

Protective devices shall include DC input fuse, AC input overcurrent protection for live circuits to be provided by service panel rated 20A maximum. AC lockout, reverse battery connection, low voltage battery disconnect (LVD), short circuit and overload protection shall be provided standard on all models. The entire LSMPs system, including batteries, shall be provided in compact cabinetry which shall have provisions for surface, recessed, T-Grid mounting. System shall be capable of providing, remote test switch, and self-test/self-diagnostics, were necessary.

System shall utilize a sealed lead calcium battery with a 10 year design life or a sealed Nickel-Cadmium battery with a 15 year design life. The charger shall be temperature compensated, dual mode type, and recharge the batteries as per UL924 guidelines. Entire system shall be tested, approved, and labeled to UL924 Emergency Lighting and Power Systems standards. T-Grid models will be plenum rated.

**WIRING DIAGRAMS**

**Diagram 1. NORMALLY ON LOADS**

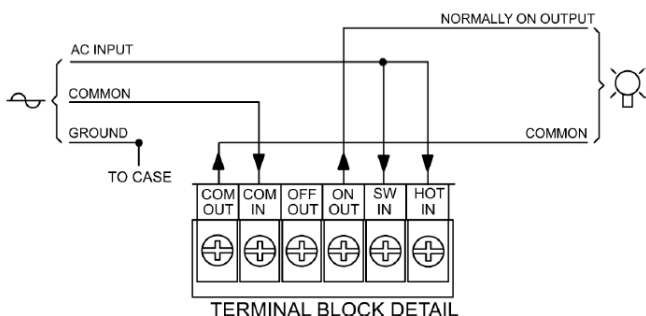

**Diagram 2. NORMALLY OFF LOADS**

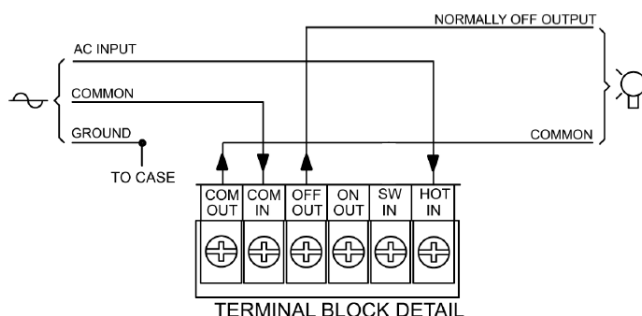

**Diagram 3. NORMALLY ON & OFF LOADS**

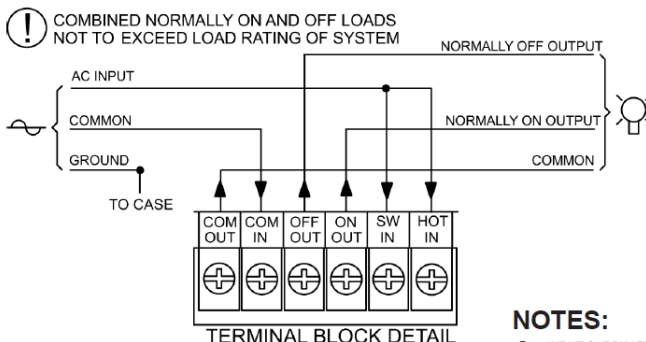

**Diagram 4. SWITCHED LOADS**

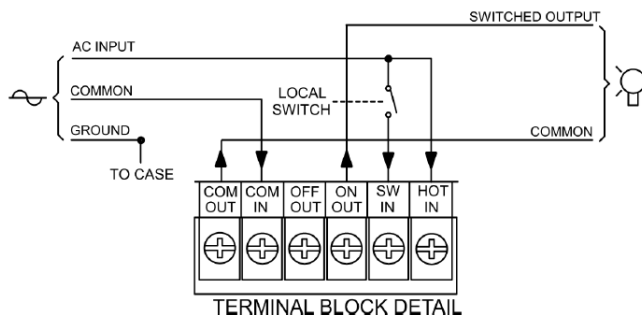

**NOTES:**

- INPUT SUPPLY FROM UNSWITCHED UTILITY RATED 20 AMPS MAXIMUM.
- OUTPUT(S) TO LIGHTING LOADS